

TECHNICAL MANUAL

OPERATOR'S and ORGANIZATIONAL MAINTENANCE MANUAL for

TEST SETS, RADIO TS-1588/AIC AND TS-1588A/AIC
(FSN 6625-00-895-6646)

CHANGE }
No. 1 }

HEADQUARTERS,
DEPARTMENT OF THE ARMY
WASHINGTON, DC, 24 May 1978

**Operator's and Organizational Maintenance Manual
FOR TEST SETS, RADIO TS-1588/AIC
(NSN 6625-00-895-6646)
AND TS-1588A/AIC
(NSN 6625-00-239-6016)**

This change is current as of 25 October 1977

TM 11-6625-441-12, 20 December 1974, is changed as follows:

1. The title is changed as shown above.
2. A vertical bar appears opposite new or changed material.
3. Remove and insert pages as indicated in the page list below:

Remove
1-1 and 1-2
3-1 and 3-2
3-5 through 3-7
4-3 and 4-4
C-1 through C-4

Insert
1-1 and 1-2
3-1 and 3-2.1
3-5 through 3-7
4-3 and 4-4
C-1 through C-5

4. File this change sheet in front of the publication for reference purposes.

By Order of the Secretary of the Army:

BERNARD W. ROGERS
General, United States Army
Chief of Staff

Official:

J. C. PENNINGTON
Brigadier General, United States Army
The Adjutant General

Distribution:

To be distributed in accordance with DA Form 12-36A, Section II, Organizational Maintenance requirements for TS-1588()/AIC.

TECHNICAL MANUAL }
 No. 11-6625-441-12 }

HEADQUARTERS
 DEPARTMENT OF THE ARMY
 WASHINGTON, DC, 20 December 1974

Operator's and Organizational
 Maintenance Manual for

TEST SETS, RADIO TS-1588/AIC AND TS-1588A/AIC
 (NSN 6625-00-895-6646)

	Paragraph	Page
CHAPTER 1. INTRODUCTION		
Section I. General		
Scope	1-1	1-1
Indexes of publications	1-2	1-1
Forms and records	1-3	1-1
Destruction of Army materiel to prevent enemy use	1-4	1-1
Administrative storage	1-5	1-1
Calibration	1-6	1-1
Reporting of errors	1-7	1-1
II. Description and data		
Purpose and use	1-8	1-1
Description	1-9	1-2
Differences between models	1-10	1-2
Tabulated data	1-11	1-2
Items comprising an operable equipment	1-12	1-2
Additional equipment required	1-13	1-2
2. SERVICE UPON RECEIPT		
Unpacking	2-1	2-1
Checking unpacked equipment	2-2	2-1
3. OPERATING INSTRUCTIONS		
Operator's controls	3-1	3-1
Preliminary starting procedure	3-2	3-2
Testing receive and interphone circuits	3-3	3-2
Testing transmit circuits	3-4	3-6
Testing hot mike and sidetone circuits	3-5	3-7
Stopping procedure	3-6	3-7
4. ORGANIZATIONAL MAINTENANCE INSTRUCTIONS		
Section I. Tools and equipment		
Scope of organizational maintenance	4-1	4-1
Tools and equipment required	4-2	4-1
II. Repainting and refinishing instructions		
Paints and finishes	4-3	4-1
Touch-up painting instructions	4-4	4-1
III. Preventive maintenance checks and services		
General	4-5	4-1
Organizational preventive maintenance checks and services	4-6	4-2
Cleaning Instructions	4-7	4-3
Equipment self-test procedure	4-8	4-3
IV. Troubleshooting and maintenance of Test Set, Radio TS-1588(*)/AIC		
Troubleshooting of Test Set, Radio TS-1588(*)/AIC	4-9	4-4
Removal and replacement	4-10	4-4
APPENDIX A. REFERENCES	A-1	A-1
B. BASIC ISSUE ITEMS LIST (BIIL) AND ITEMS TROOP INSTALLED OR AUTHORIZED LIST (ITIAL) (Non applicable)		
C. MAINTENANCE ALLOCATION		
I. Introduction	C-1	C-1
II. Maintenance allocation chart	C-3	C-1

*This manual supersedes TM 11-6625-441-12, 15 August 1961, including all changes.

CHAPTER 1 INTRODUCTION

Section I. GENERAL

1-1. Scope

a. This manual describes and covers operator and organizational maintenance functions for Test Set, Radio TS-1588/AIC (fig. 1-1) and TS-1588 A/AIC (fig. 1-2). Included are instructions for operation, cleaning, and inspection of the equipment, and replacement of parts available to organizational level maintenance.

b. Official nomenclature and type designations, including the symbol (*), is used to identify all models of the equipment covered by this manual. Therefore, Test Set, Radio TS-1588 (*)/AIC represents Test Set, Radio TS-1588/AIC and TS-1588A/AIC.

1-2. Indexes of Publications

a. *DA Pam 310-4.* Refer to the latest issue of DA Pam 310-4 to determine whether there are new editions, changes, or additional publications pertaining to the equipment.

b. *DA Pam 310-7.* Refer to DA Pam 310-7 to determine whether there are modification work orders (MWO's) pertaining to the equipment.

1-3. Forms and Records

a. *Reports of Maintenance and Unsatisfactory Equipment.* Maintenance forms, records, and reports which are to be used by maintenance personnel at all maintenance levels are listed in and prescribed by TM 38-750.

b. *Report of Packaging and Handling Deficiencies.* Fill out and forward DD Form 6 (Report of Packaging and Handling Deficiencies) as prescribed in AR 700-58/NAVSUPINST 4030.29/AFR 71-13/MCO P4030.29A, and DLAR 4145.8.

c. *Discrepancy in Shipment Report (DISREP) (SF 361).* Fill out and forward Discrepancy in shipment Report (DISREP)(SF 361) as prescribed in AR 55-38 (Army) NAVSUPINST 4610.33B/AFM 75-18/MCO P4610.19C and DLAR 4500.15.

1-4. Destruction of Army Materiel to Prevent Enemy Use

Destruction of Army materiel to prevent enemy use shall be as prescribed in TM 750-244-2.

1-5. Administrative Storage

Administrative storage of Test Sets, Radio TS-1588(*)/AIC is for periods of 1 to 45 days and may be accomplished as follows:

a. *Storage site.* The equipment should be stored in an area specifically marked "Administrative Storage". The area should be covered and protected from the elements.

b. *Maintenance Services.* Prior to storage, perform the next scheduled major preventive maintenance service.

c. *Inspection.* Inspect the equipment for proper operation before storage. Do not store inoperable equipment.

d. *Protection.* Protect the equipment by storing in barrier material (NSN 8135-00-282-0565) along with a dessicant bag (NSN 6850-00-264-6572).

1-6. Calibration

No calibration is authorized at any category of maintenance for this equipment.

1-7. Reporting of Errors

The reporting of errors, omissions, and recommendations for improving this publication by the individual is encouraged. Reports should be submitted on DA Form 2028 (Recommended Changes to Publications and Blank Forms) and forwarded direct to Commander, US Army Communications and Electronics Materiel Readiness Command, ATTN: DRSEL-MA-Q, Fort Monmouth, NJ 07703.

1-7.1. Reporting Equipment Improvement Recommendations

EIR will be prepared using DA Form 2407 (Maintenance Request). Instructions for preparing EIR's are provided in TM 38-750, the Army Maintenance Management System. EIR's should be mailed directly to Commander, US Army Communications and Electronics Materiel Readiness Command, ATTN: DRSEL-MA-Q, Fort Monmouth, NJ 07703.

Section II. DESCRIPTION AND DATA

1-8. Purpose and Use

a. *Purpose.* Test Set, Radio TS-1588(*)/AIC (figs. 1-1 and 1-2) contains switches, cables, and connec-

tors to facilitate the interconnection and control of test equipment to bench test all the circuits of Control, Intercommunications Set C-1611D/AIC.

TM 11-6625-441-12

b. Use. Test Set, Radio TS-1588(*)/AIC is used to bench test Control, Intercommunications Set C-1611D/AIC. The TS-1588(*)/AIC connects a power supply, a headset-microphone, an audio oscillator, an output meter, and a multimeter to the equipment under test and permits visual and aural monitoring of the interphone transmitting and receiving circuits of the C-1611D/AIC. Also included are built-in facilities for self-testing internal circuits of the TS-1588(*)/AIC.

1-9. Description

a. The TS-1588(*)/AIC (interphone test set) (figs. 1-1 and 1-2) is enclosed in a rectangular metal case that has a removable hinged cover. The cover is secured to the case with fasteners on the front and sides of the case. A handle attached to the case enables the operator to hand-carry the interphone test set to the test area. All connectors and operating controls are on the front panel.

b. A storage compartment on the left side of the interphone test set is used for storing the power and test cables. In addition to the cables, running spares are included in the storage compartment of the TS-1588*/AIC. The power cable consists of a two-conductor cable with insulated battery clips connected to one end. The test cable is terminated in a 37-pin test cable plug. A hinged panel of the cover is used to store maintenance manuals. In the lower left section of the front panel is a 37-pin self-test receptacle beneath a protective cover.

c. Four rotary selector switches are on the lower right section of the front panel. Three toggle switches, three indicator lights and two fuseholders are on the upper left section of the panel. Six binding posts (input test jacks) and a headset jack are on the lower left section of the panel.

1-10. Differences Between Models

The two basic configuration of Test Set, Radio TS-1588(*)/AIC are identical except for the addition of an EMER position on RECEIVER SEL switch and an ALTN position on TRANSMITTER SEL switch and accompanying circuitry installed on Test Set, Radio TS-1588A/AIC. The EMER position of the RECEIVER SEL switch and the ALTN position of TRANSMITTER SEL switch provide test and check out capability for the emergency receiver audio input circuitry and the alternate transmitter number 1 audio output circuitry respectively, of Control, Intercommunication Set C-1611D/AIC (interphone control).

1-11. Tabulated Data

a. Physical

Weight14 pounds

Dimensions 16¾ inches long 7½ inches deep 10 inches wide

b. Electrical

Power requirements:

Static28 vdc, 0.05 ampere (1.4 watts)

Under test28 vdc. 0.5 ampere (14 watts)

Headset-microphone input impedance:

Microphone input impedance8 ohms

Headset output impedance8 ohms

Audio oscillator input impedance:

Receive circuits input impedance .. 75 ohms

Transmit circuits input impedance .. 5,000 ohms

Output meter input impedance150 ohms

1-12. Items Comprising An Operable Equipment

Test Set, Radio TS-1588(*)/AIC (NSN 6625-00-895-6646) and one set of running spares consisting of 12 spare 1-ampere fuses and 2 spare indicator lamps comprise an operable equipment.

1-13. Additional Equipment Required

The following equipment is not supplied as part of the interphone test set but is needed for use with it.

a. *Headset-Microphone.* A headset-microphone (Headset-Microphone H-101A/U or equivalent) is required to apply voice signals to, and monitor voice signals from, the interphone control under tests. The headset-microphone is plugged into the HDST MIC jack on the interphone test set front panel.

b. *Audio Oscillator.* An audio oscillator (Audio Oscillator TS-421A/U or equivalent) is required to supply audio signals to the circuits of the interphone control. It is connected to the AUDIO OSC binding posts on the interphone test set front panel.

c. *Output Meter.* An output meter (Output Meter TS-585A/U or equivalent) is required to monitor the output audio signals from the circuits of the interphone control. It is connected to the OUTPUT MTR binding posts on the interphone test set front panel.

d. *Multimeter.* A multimeter (Electronic Multimeter TS-505D/U or equivalent) is required to measure the input voltage applied to the interphone test set. It is connected to the +28V and GND binding posts on the interphone test set front panel.

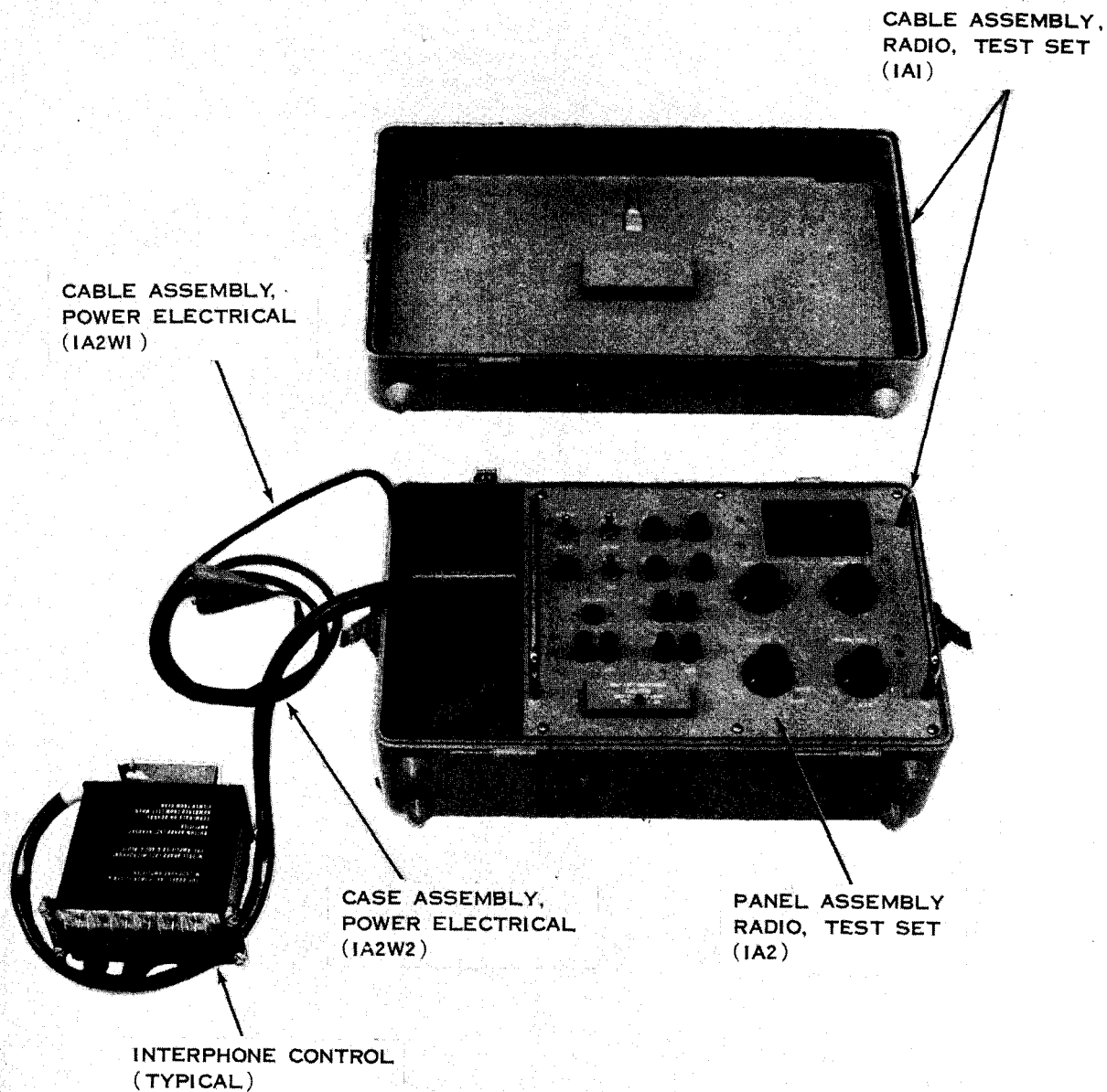

EL6625-441-12-TM-2

Figure 1-2. Test Set, Radio TS-1588A/AIC, connected to interphone control under test.

CHAPTER 2

SERVICE UPON RECEIPT

2-1. Unpacking

a. Packaging Data. When packed for shipment, the interphone test set is placed in a corrugated cardboard box lined with a resilient filler material. A typical packaging diagram is shown in figure 2-1. The shipping box is 19 inches long by 12 inches wide by 10 inches deep and weighs 15 pounds.

b. Removing Contents.

(1) Cut the waterproof tape that seals the top of the corrugated box and open the flaps.

(2) Remove the filler material from the top and sides of the corrugated box.

(3) Lift the interphone test set from the corrugated box.

(4) Remove the interphone test set cover by releasing the fasteners, and opening and sliding the cover from the hinge pins.

(5) Remove the running spares from the storage compartment.

(6) Uncoil the power and test cables.

2-2. Checking Unpacked Equipment

a. Inspect the equipment for damage incur-

red during shipment. If the equipment has been damaged, report the damage on DD Form 6 (para 1-3).

b. Check the equipment against the items comprising an operable equipment (para 1-12) and the packing slip to see if the shipment is complete. Report all discrepancies in accordance with the instructions of TM 38-750. The equipment should be placed in service even though a minor assembly or part that does not affect proper functioning is missing.

c. Check to see whether the equipment has been modified. (Equipment which has been modified will have the MWO number on the front panel, near the nomenclature plate.) Check also to see whether all currently applicable MWO's have been applied. (Current MWO's applicable to the equipment are listed in DA Pamphlet 310-7).

d. After checking is completed, coil and place the interphone test set power and test set cables in the storage compartment, reinstall the interphone test set cover on the hinge pins, close the cover, and secure the fasteners.

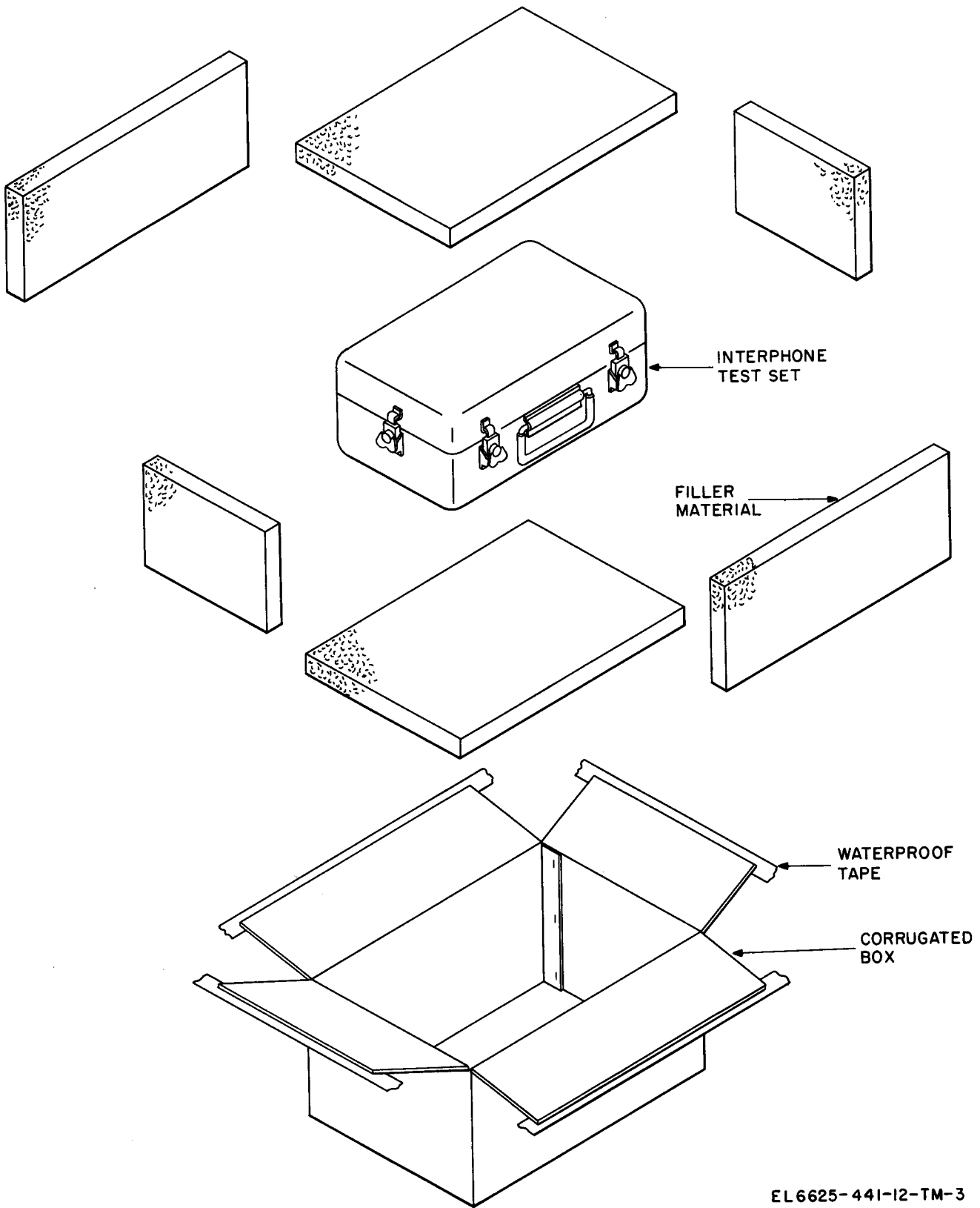

EL 6625-441-12-TM-3

Figure 2-1. Typical packaging diagram.

CHAPTER 3 OPERATING INSTRUCTIONS

3-1. Operator's Controls

(figs. 3-1, 3-2, and 3-3)

Table 3-1 lists and describes those controls, indicators and connectors used by the operator of interphone test set.

Table 3-1. Operator's Controls

<i>Control, indicator or connector</i>	<i>Function</i>										
POWER-OFF switch	In POWER position, turns on the interphone test set. In OFF position, turns off the interphone test set.										
KEYING switch (spring-loaded; normally in midposition).	In RADIO position, energizes radio transmission control circuit of the interphone control. In mid position, interphone control is in the receiving position. In INTER position, energizes interphone transmission control circuit of the interphone control.										
SIGNAL switch (spring-loaded; normally in METER position).	a. In METER position, applies AUDIO OSC input to transmission audio input of interphone control, when INPUT SEL switch is set to T. Also applies the interphone control output (selected by OUTPUT SEL switch) to OUTPUT MTR binding posts. b. In HD MIC position, applies HDST MIC audio to transmission audio input of the interphone control. Also applies selected interphone control output to HDST MIC jack.										
OUTPUT SEL 4-position rotary switch.	Selects and applies audio output of the interphone control to OUTPUT MTR or HDST MIC connectors as follows: <table border="0" style="margin-left: 20px;"> <thead> <tr> <th style="text-align: left;"><i>Switch position</i></th> <th style="text-align: left;"><i>Action</i></th> </tr> </thead> <tbody> <tr> <td>R</td> <td>Selects headset audio output.</td> </tr> <tr> <td>T</td> <td>Selects transmission audio output.</td> </tr> <tr> <td>I</td> <td>Selects interphone line audio input.</td> </tr> <tr> <td>C</td> <td>Not used.</td> </tr> </tbody> </table>	<i>Switch position</i>	<i>Action</i>	R	Selects headset audio output.	T	Selects transmission audio output.	I	Selects interphone line audio input.	C	Not used.
<i>Switch position</i>	<i>Action</i>										
R	Selects headset audio output.										
T	Selects transmission audio output.										
I	Selects interphone line audio input.										
C	Not used.										

Table 3-1. Operator's Controls - Continued

<i>Control, indicator or connector</i>	<i>Function</i>														
INPUT SEL 3-position rotary switch.	Applies AUDIO OSC input to interphone control audio input circuits, as follows: <table border="0" style="margin-left: 20px;"> <thead> <tr> <th style="text-align: left;"><i>Switch position</i></th> <th style="text-align: left;"><i>Action</i></th> </tr> </thead> <tbody> <tr> <td>R</td> <td>Applies audio to the receiver circuit selected by RECEIVER SEL switch.</td> </tr> <tr> <td>T</td> <td>Applies audio to transmission audio input circuit, when SIGNAL switch is set to METER. Applies audio to private interphone line and input circuits.</td> </tr> </tbody> </table>	<i>Switch position</i>	<i>Action</i>	R	Applies audio to the receiver circuit selected by RECEIVER SEL switch.	T	Applies audio to transmission audio input circuit, when SIGNAL switch is set to METER. Applies audio to private interphone line and input circuits.								
<i>Switch position</i>	<i>Action</i>														
R	Applies audio to the receiver circuit selected by RECEIVER SEL switch.														
T	Applies audio to transmission audio input circuit, when SIGNAL switch is set to METER. Applies audio to private interphone line and input circuits.														
RECEIVER SEL switch. Nine-position rotary on TS-1588/AIC; ten position rotary on TS-1588A/AIC.	Applies audio oscillator input to interphone control receiver circuit corresponding to selected positions as follows: <table border="0" style="margin-left: 20px;"> <thead> <tr> <th style="text-align: left;"><i>Switch position</i></th> <th style="text-align: left;"><i>Action</i></th> </tr> </thead> <tbody> <tr> <td>OFF</td> <td>Deactivates audio inputs.</td> </tr> <tr> <td>1 through 4</td> <td>Applies audio input to receivers 1 through 4.</td> </tr> <tr> <td>5</td> <td>Applies audio input to marker beacon receiver.</td> </tr> <tr> <td>6</td> <td>Applies audio input to VHF navigation receiver.</td> </tr> <tr> <td>7</td> <td>Applies audio input to navigational low frequency receiver.</td> </tr> <tr> <td>INTER</td> <td>Applies audio input to private interphone line and interphone receiver.</td> </tr> </tbody> </table>	<i>Switch position</i>	<i>Action</i>	OFF	Deactivates audio inputs.	1 through 4	Applies audio input to receivers 1 through 4.	5	Applies audio input to marker beacon receiver.	6	Applies audio input to VHF navigation receiver.	7	Applies audio input to navigational low frequency receiver.	INTER	Applies audio input to private interphone line and interphone receiver.
<i>Switch position</i>	<i>Action</i>														
OFF	Deactivates audio inputs.														
1 through 4	Applies audio input to receivers 1 through 4.														
5	Applies audio input to marker beacon receiver.														
6	Applies audio input to VHF navigation receiver.														
7	Applies audio input to navigational low frequency receiver.														
INTER	Applies audio input to private interphone line and interphone receiver.														

Table 3-1. Operator's Controls - Continued

Control, indicator or connector	Function								
	<table border="1"> <thead> <tr> <th>Switch position</th> <th>Action</th> </tr> </thead> <tbody> <tr> <td>EMER (TS-1588A/AIC only)</td> <td>Applies audio input to emergency receiver audio in.</td> </tr> </tbody> </table>	Switch position	Action	EMER (TS-1588A/AIC only)	Applies audio input to emergency receiver audio in.				
Switch position	Action								
EMER (TS-1588A/AIC only)	Applies audio input to emergency receiver audio in.								
TRANSMITTER SEL switch. (Five position double wafer rotary on TS-1588/AIC; six position double wafer rotary on TS-1588A/AIC.)	Selects the interphone control transmitter control output, and transmitter audio output to OUTPUT and MTR-GND binding posts when OUTPUT SEL switch is set to T. Selected positions areas follows:								
	<table border="1"> <thead> <tr> <th>Switch position</th> <th>Action</th> </tr> </thead> <tbody> <tr> <td>OFF</td> <td>Deactivates interphone control transmitter control output and transmitter audio output.</td> </tr> <tr> <td>1 through 4</td> <td>Selects transmitters 1 through 4 control output and audio output.</td> </tr> <tr> <td>ALT on TS-1588A/AIC only</td> <td>Selects alternate transmitter 1 audio output and transmitter 1 control output.</td> </tr> </tbody> </table>	Switch position	Action	OFF	Deactivates interphone control transmitter control output and transmitter audio output.	1 through 4	Selects transmitters 1 through 4 control output and audio output.	ALT on TS-1588A/AIC only	Selects alternate transmitter 1 audio output and transmitter 1 control output.
Switch position	Action								
OFF	Deactivates interphone control transmitter control output and transmitter audio output.								
1 through 4	Selects transmitters 1 through 4 control output and audio output.								
ALT on TS-1588A/AIC only	Selects alternate transmitter 1 audio output and transmitter 1 control output.								
KEY ON lamp	Lights when selected transmitter control circuit is energized (when KEYING switch is set to RADIO). Lights when PRESS TO TEST ring is depressed.								
OPERATE lamp	Lights when POWER-OFF switch is set to POWER. Lights when PRESS TO TEST ring is depressed.								
SELF TEST indicator light.	Lights when test cable connector is plugged into SELF TEST RECEPTACLE. Lights when lamp PRESS TO TEST feature is depressed, with POWER-OFF switch set to POWER and test cable connector not plugged into SELF TEST RECEPTACLE.								
HDST-MIC jack.	Connects headset-microphone to the interphone test set.								

Table 3-1. Operator's Controls - Continued

Control, indicator or connector	Function
+28V and GND binding posts.	Monitors the 28-Vdc power source connected to the interphone test set.
OUTPUT MTR binding posts.	Connects audio output meter to the interphone test set.
AUDIO OSC binding posts.	Connects audio oscillator to the interphone test set.
SELF TEST RECEPTACLE J8 (fig. 3-3).	Used to perform operational check of interphone test set circuits when test cable plug is plugged into this receptacle.

3-2. Preliminary Starting Procedure

(figs. 3-1 and 3-2)

- a. Set the POWER-OFF switch to OFF.
- b. Insert the test cable plug into the connector on the interphone control to be tested. The connector is located at the rear of the interphone control.
- c. Connect the test equipment to the connectors on the front panel of the interphone test set as shown in figure 3-4.
- d. Be sure that the 28-vdc power supply is turned off. Connect the interphone test set to the 28-vdc power supply. The red insulated battery clip connects to the positive side of the powerline; the black insulated clip connects to the ground (negative) side.

CAUTION

- Adjust the multimeter to the 50 VDC scale, the output meter to 500 milliwatts and the power supply for 27.5 ± 0.5 vdc. Maintain the power supply voltage at 27.5 ± 0.5 vdc throughout the test.
- e. Energize the test equipment and allow a 5-minute warmup period.
 - f. Set the POWER-OFF switch to POWER; check to see that the OPERATE lamp lights. If the OPERATE lamp does not light, refer to procedures in paragraphs 4-9 and 4-10.
 - g. Adjust the audio oscillator for an output frequency of 1,000 Hertz (Hz); maintain this frequency throughout the tests.

3-3. Testing Receive and Interphone Circuits

(figs. 3-1 and 3-2)

- a. Perform the preliminary starting procedure (para 3-2).
- b. Set the interphone test set controls to the following positions:
 - (1) OUTPUT SEL switch to R.
 - (2) INPUT SEL switch to R.
 - (3) RECEIVER SEL switch to 1.
 - (4) TRANSMITTER SEL switch to OFF.
- c. Set the controls of the interphone control to the following positions:

- (1) VOL control fully clockwise (cw).
 - (2) RECEIVERS switches to off (down).
 - (3) Transmit-interphone selector switch to 1.
- d.* Adjust the audio oscillator for 0.5-volt rms output. Measure this output at the AUDIO OSC jacks on the TS-1588(*)/AIC using a multimeter or ACVTVM with all cables connected.
- e.* Set the output meter for 8 ohms impedance.

f. Simultaneously rotate interphone test set RECEIVER SEL switch and interphone control transmit-interphone selector switch to positions 1, 2, 3, and 4; the output meter should indicate 110 \pm 48 mW.

NOTE

If output meter indication is not within

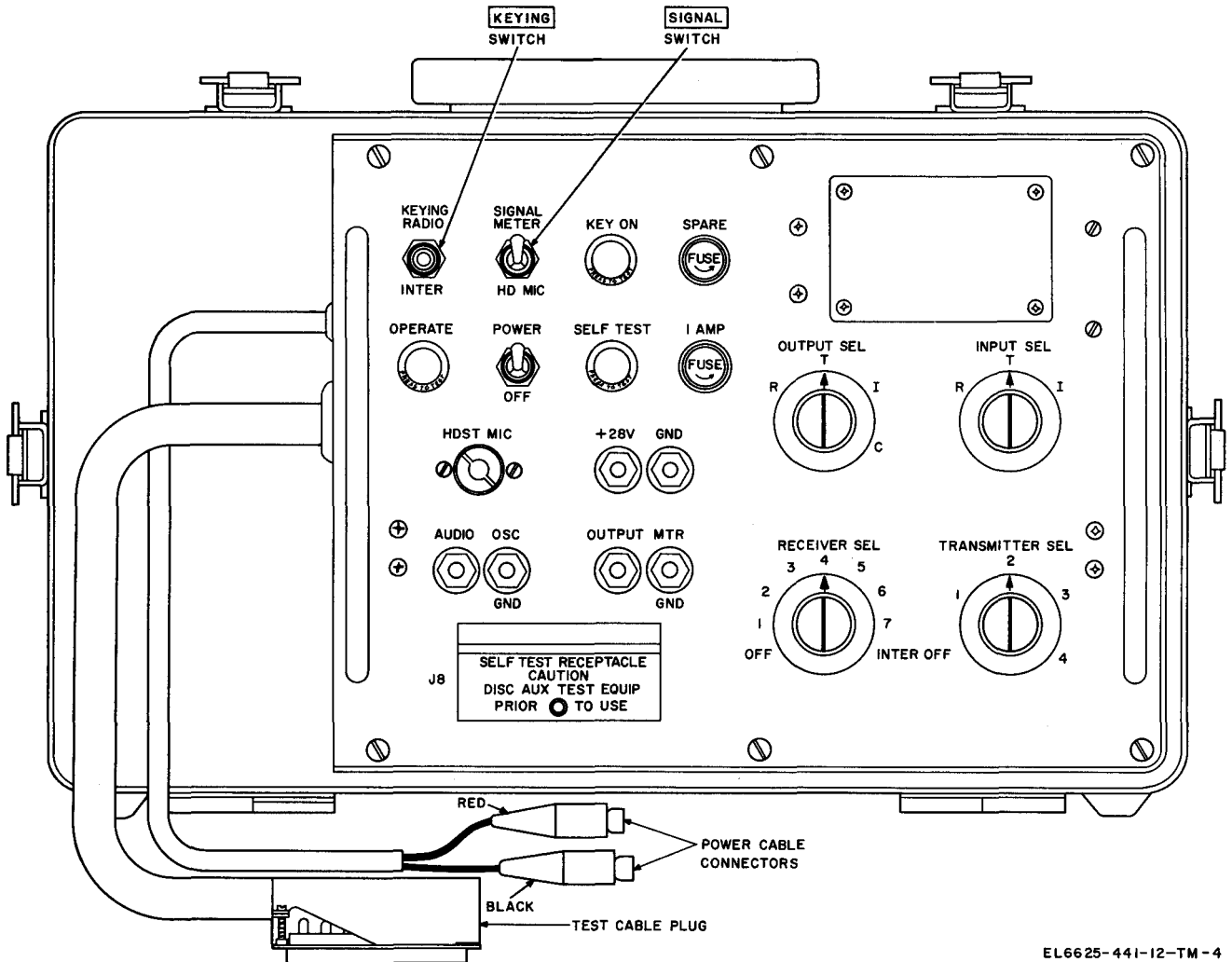

EL6625-441-12-TM-4

Figure 3-1. Test Set, Radio TS-1588/AIC, operating controls and indicators.

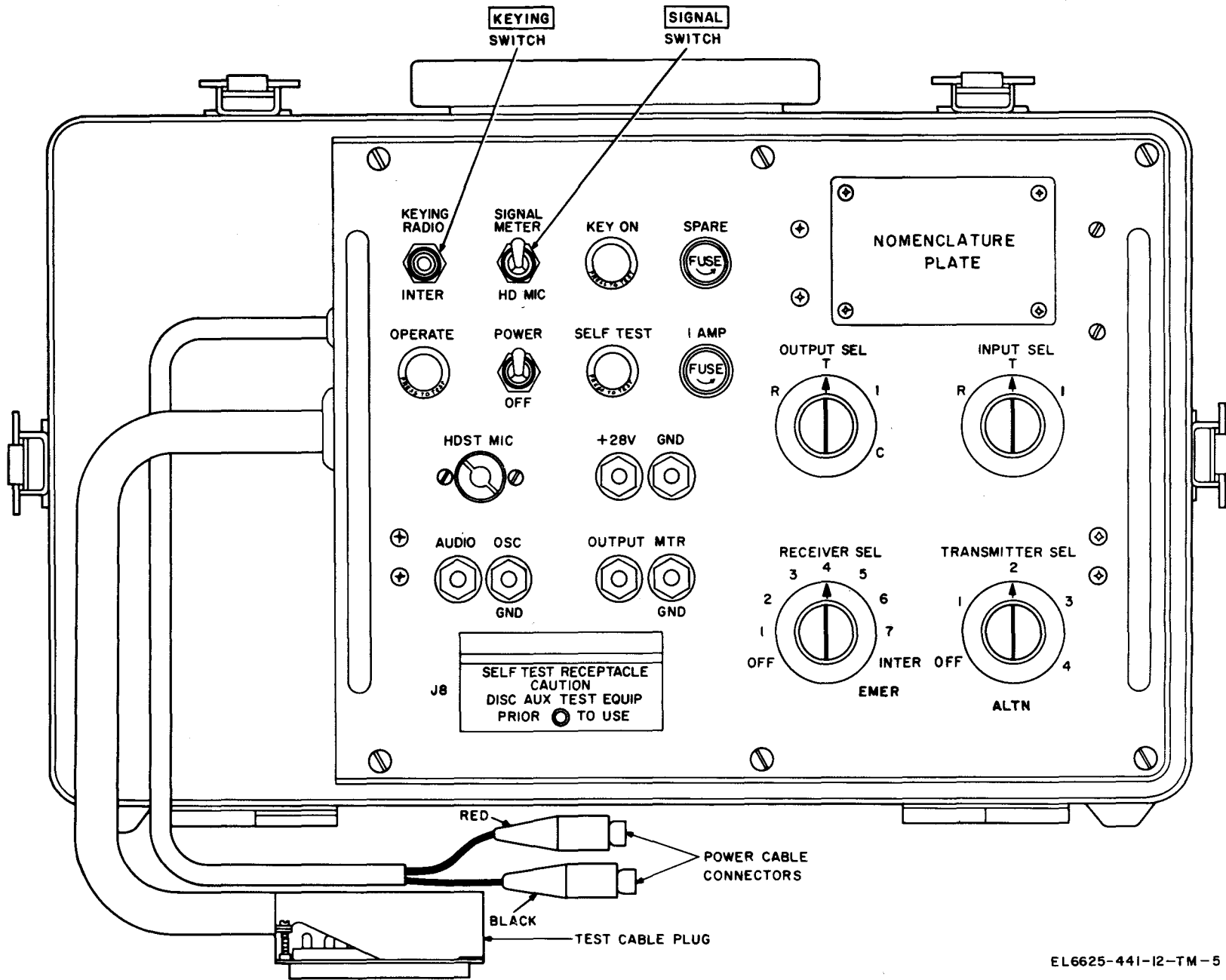
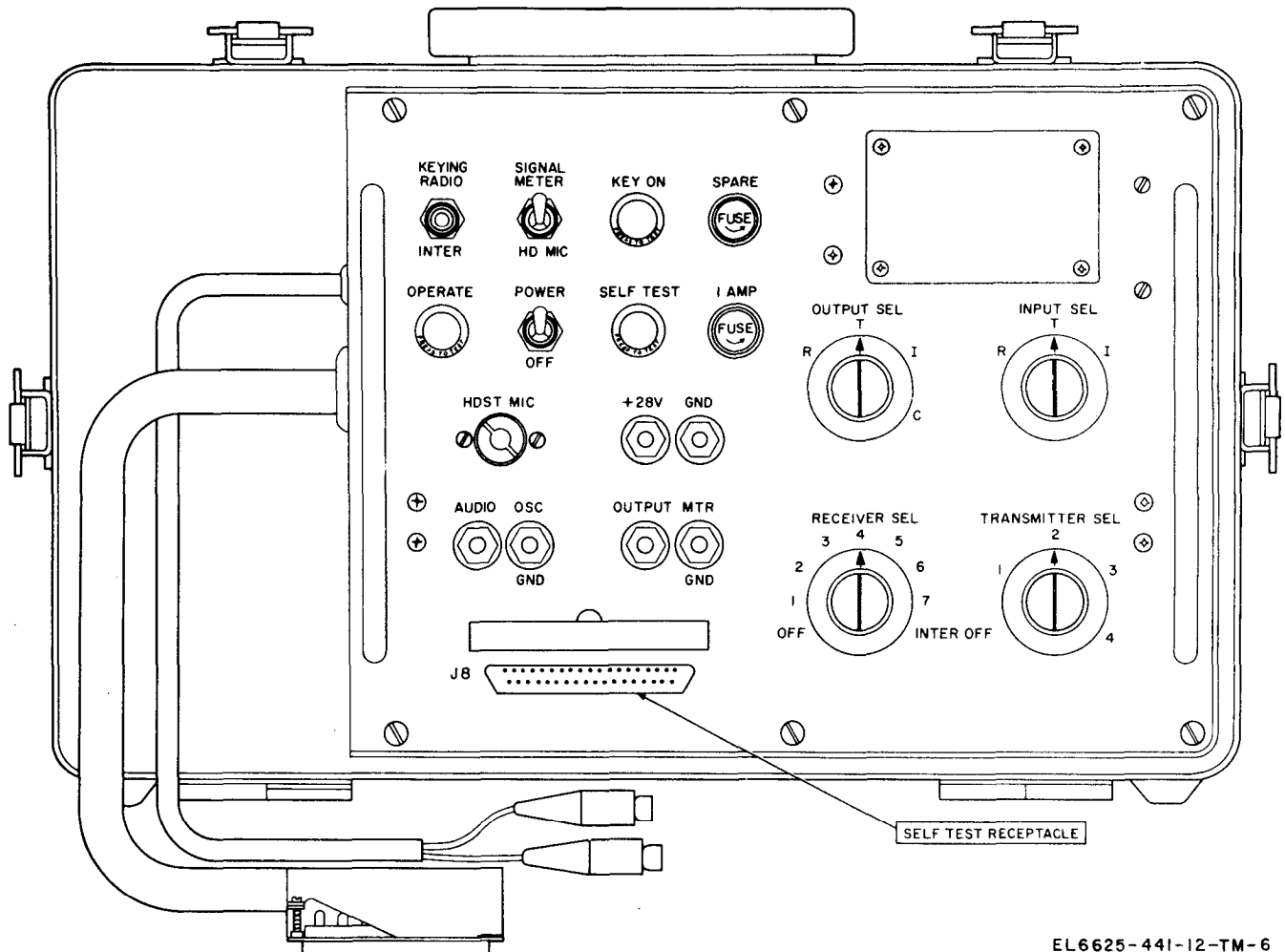

Figure 3-2. Test Set, Radio TS-1588A/AIC, operating controls and indicators.



EL6625-441-12-TM-6

Figure 3-3. SELF TEST RECEPTACLE J8, with cover opened.

the tolerances of f above, troubleshooting of the interphone control is required.

g. Return interphone test set RECEIVER SEL switch to position 1, and set interphone control transmit-interphone selector switch to position INT.

h. Rotate interphone test set RECEIVER SEL switch from position 1 through 7; the output meter should read zero.

i. Rotate interphone test set RECEIVER SEL switch to INTER; the output meter should indicate 110 ± 48 mW.

j. On Test Set, Radio TS-1588A/AIC, rotate interphone test set RECEIVER SEL switch to EMER; the output meter should indicate 27 ± 12 mW.

k. Return Test Set, Radio TS-1588A/AIC interphone test set RECEIVER SEL switch to position 1.

j. Set interphone control RECEIVERS switches NAV and 1 through 4 to ON (up position).

m. Rotate interphone test set RECEIVER SEL switch from position 1 through 6; the output meter

should indicate 110 ± 48 mW. Pause at each position, and vary interphone control VOL control from fully clockwise to fully counterclockwise and back to fully clockwise; the output meter indication should vary from 0 to 110 ± 48 mW.

n. Rotate interphone test set RECEIVER SEL switch to position 7; the output meter should indicate $27 + 12$ mW. Vary interphone control VOL control from fully clockwise to fully counterclockwise and back to fully clockwise; the output meter should not vary.

o. On Test Set, Radio TS-1588A/AIC, rotate interphone test set RECEIVER SEL switch to EMER; the output meter should indicate $27 + 12$ mW. Vary interphone control from fully clockwise to fully counterclockwise and back to fully clockwise; the output meter should not vary.

p. Set interphone control RECEIVERS switches NAV and 1 through 4 to OFF (down) position, and RECEIVERS INT switch to ON (up) position.

q. Set interphone control transmit-interphone selector switch to position 1.

r. Rotate interphone test set RECEIVER SEL

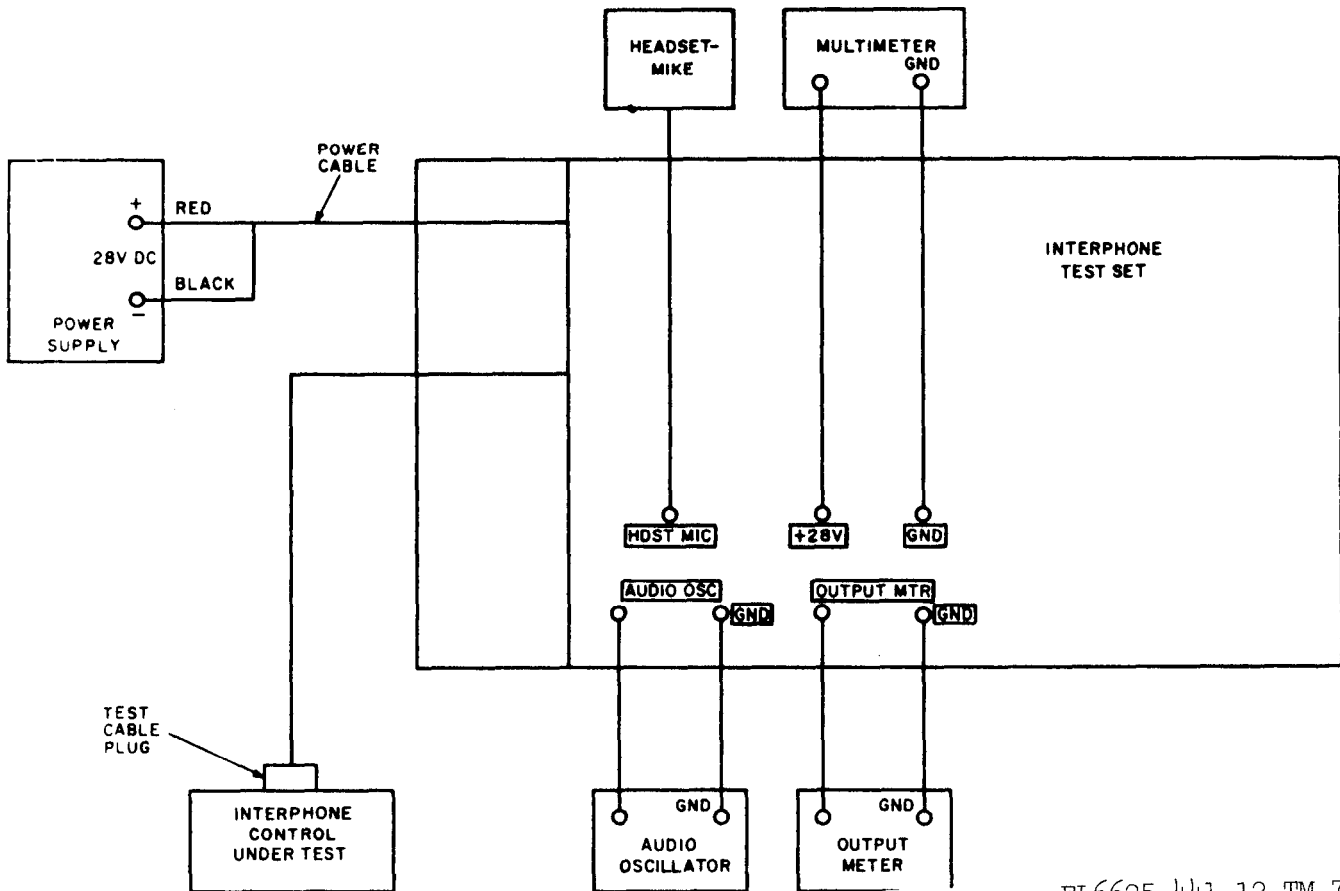

EL6625-441-12-TM-7

Figure 3-4. Test connections.

switch to INTER; the output meter should indicate 110 +48 mW.

s. Set interphone control transmit-interphone selector switch to INT, and RECEIVERS INT switch to OFF (down position).

t. If testing of transmit circuits is not required, perform the stopping procedure (para 3-6).

3-4. Testing Transmit Circuits

(figs. 3-1 and 3-2)

a. Perform the preliminary starting procedure (para 3-2).

b. Set the interphone test set controls to the following positions:

- (1) OUTPUT SEL switch to T.
- (2) INPUT SEL switch to T.
- (3) RECEIVER SEL switch to OFF.
- (4) TRANSMITTER SEL switch to 1.

c. Set the controls of the interphone control to the following positions:

- (1) VOL control to midposition.
- (2) RECEIVERS switches to OFF (down).
- (3) Transmit-interphone selector to 1.

d. Adjust the audio oscillator for a 0.425-volt output.

e. Adjust the output meter for 150 ohms impedance.

f. Place the interphone test set KEYING switch in the RADIO position and hold; check to see that the KEY ON lamp lights. The output meter will indicate 18 to 71 milliwatts (mW).

g. Release the KEYING switch.

h. Rotate the interphone test set TRANSMITTER SEL switch and the interphone control transmit-interphone selector switches in unison to positions 2, 3, and 4. At each position, hold the KEYING switch to the RADIO position. Check to see that the KEY ON lamp lights and the output meter indicates 18 to 71 milliwatts.

i. Rotate the interphone test set OUTPUT SEL switch to I and hold the KEYING switch in the INTER position. The output meter should indicate 18 to 71 mW.

j. Set the interphone control transmit-interphone selector switch to INT, and hold the KEYING switch in the RADIO position. The output meter should indicate 18-71 mw.

k. Rotate the interphone test set OUTPUT SEL switch to R.

l. Rotate the interphone test set RECEIVER

SEL switch to INTER.

m. Turn the interphone control VOL control to mid-position.

n. Place the interphone test set SIGNAL switch to HD MIC and hold. Place the KEYING switch to INTER and hold.

o. Speak into the microphone. Sidetone should be heard in the headset.

p. Perform the stopping procedure (para 3-6).

3-5. Testing Hot Mike and Sidetone Circuits

(figs. 3-1 and 3-2)

a. Perform the preliminary starting procedure (para 3-2).

b. Place interphone control transmit-interphone selector switch to the INT position.

c. Rotate interphone test set OUTPUT SEL switch to position R and RECEIVER SEL switch to the INTER position.

d. Position the headset microphone in place on operator's head.

e. Place and hold interphone test set SIGNAL switch to HD MIC and KEYING switch to INTER.

f. Speak into the mike and slowly rotate interphone control VOL control fully clockwise;

sidetone should be audible from the headset.

g. Release interphone test set SIGNAL switch and KEYING switch; sidetone shall cease.

h. Rotate interphone control transmit-interphone selector switch to PVT position.

i. Place and hold interphone test set SIGNAL switch to HD MIC.

j. Speak into the mike; sidetone should be audible from the headset.

k. Release interphone test set SIGNAL switch; sidetone shall cease.

l. If further testing is not required, perform the stopping procedure (para 3-6).

3-6. Stopping Procedure

a. Set the POWER-OFF switch (figs. 3-1 and 3-2) to OFF.

b. Turn the 28-vdc power supply off and disconnect the interphone test set power cable from the 28-vdc power source.

c. Disconnect the interphone test set test cable from the interphone control; roll and store the cables in the cable storage compartment.

d. Disconnect the audio oscillator, output meter, and multimeter from the interphone test set.

CHAPTER 4

ORGANIZATIONAL MAINTENANCE INSTRUCTIONS

Section I. TOOLS AND EQUIPMENT

4-1. Scope of Organizational Maintenance.

This chapter contains instructions covering organizational maintenance of Test Set, Radio TS-1588(*)/AIC. The instructions include the following duties to be performed by the organizational maintenance man. The tools and equipment required are found in paragraph 4-2.

a. Organizational preventive maintenance checks and services (para 4-6).

- b.* Cleaning (para 4-7).
- c.* Troubleshooting (para 4-9).
- d.* Removal and replacement (4-10).

4-2. Tools and Equipment Required

- a.* Tool Kit, Electronic Equipment TK-105/G.
- b.* Trichloroethane.
- c.* Bruch, MIL-G-7241.
- d.* Fine sandpaper, No. 000.
- e.* Lint-free cloth.

Section II. REPAINTING AND REFINISHING INSTRUCTIONS

4-3. Paints and Finishes

When Test Set, Radio TS-1588(*)/AIC requires repainting, refinishing, or touch up painting, use a lusterless gray paint, Color No. 36118 as listed in Federal Standard No. 595a, or equivalent. Equivalent paint is listed in SB 11-573 under National stock number 8010-00-297-0549. Refer to SB 11-573 for painting tools and miscellaneous supplies.

4-4. Touch-up Painting Instructions

a. Refer to TB 746-10 for instructions on painting and preserving Electronics Command equipment. In touchup painting, a perfect match with the exact shade of the original paint surface may not be possible. There are many reasons for this, such as change in the original pigment because of oxidation and differences as a result of manufacture. The prevention of corrosion and deterioration is the most important consideration in touchup painting, appearance is secondary. This, however, should not be construed to mean that appearance of the equipment is not important. Touchup painting should be accomplished neatly and with good workmanship. Inspection personnel should make al-

lowances for slight color mismatch where minor touchup has been done, but not for neglect, poor workmanship, or in cases where the need for refinishing is obvious.

b. Remove rust and corrosion from metal surfaces by lightly sanding them with fine sandpaper. Brush two thin coats of paint on the bare metal to protect it from further corrosion.

c. *Periodic Preventive Maintenance Checks and Services.* The maintenance functions indicated in the periodic preventive maintenance checks and services table (table 4-3) are performed once each periodic interval in addition to the daily and intermediate preventive maintenance checks and services (table 4-1 and 4-2). A periodic interval is defined as approximately 120 calendar days of 8-hour-per-day operation. All deficiencies or shortcomings will be recorded, and those not corrected during the preventive maintenance checks and services will be immediately reported to higher category of maintenance by use of forms and procedures specified in TM 38-750. Equipment that has a deficiency that cannot be corrected at organization should be deadlined in accordance with TM 38-750.

Section III. PREVENTIVE MAINTENANCE CHECKS AND SERVICES

4-5. General

To be sure that the Test Set, Radio TS-1588(*)/

AIC is always ready for operation, inspect it systematically so that defects may be disco-

vered and corrected before they result in serious damage or failure. The necessary preventive maintenance checks and services to be performed are listed in tables 4-1, 4-2, and 4-3. The item numbers indicate the sequence of minimum inspection requirements. Defects discovered during operation of the unit will be noted for future correction to be made as soon as operation has ceased. Stop operation immediately if a deficiency is noted during operation which would damage the equipment. Record all deficiencies together with the corrective action in accordance with the procedures contained in TM 38-750.

4-6. Organizational Preventive Maintenance Checks and Services

Organizational preventive maintenance checks and services consist of daily preventive maintenance checks and services, intermediate preventive maintenance checks and services, and periodic preventive maintenance checks and services.

a. Daily Preventive Maintenance Checks and Services. Perform the maintenance functions indicated in the daily preventive maintenance checks and services (table 4-1) on a daily basis. Table 4-1 specifies preventive maintenance checks and services that must be performed daily or under the conditions listed below.

(1) When the equipment is initially received.

(2) When the equipment has been returned after higher category maintenance.

(3) At least once each week if the equipment is maintained in a standby condition.

b. Intermediate Preventive Maintenance Checks and Services. The maintenance functions indicated in the intermediate preventive maintenance checks and services table (table 4-2) are performed once each intermediate interval in addition to the daily preventive maintenance checks and services (table 4-1). An intermediate interval is defined as approximately 30 calendar days of an 8-hour-per-day operation. Adjustment of the maintenance interval must be made to compensate for any unusual operating conditions. Equipment maintained in a standby (ready for immediate operation) condition must have intermediate maintenance performed. Equipment in limited storage (requires service before operation) does not require intermediate maintenance.

Table 4-1. Daily Preventive Maintenance Checks and Services

Sequence No.	ITEM TO BE INSPECTED PROCEDURE	Work time (M/H)
1.	EXTERIOR SURFACES Clean the interphone test set case, cover, and front panel. Cleaning instructions are contained in paragraph 4-7.	
2.	SWITCHES, INDICATORS, AND BINDING POSTS a. Check switches, indicators, and binding posts for loose or insecure fastenings; tighten if required. b. Switches should operate smoothly and knobs should be properly secured to shafts and should not bind. Tighten loose knobs and be sure they do not rub against the panel. Replace broken or defective knobs.	
NOTE		
The KEYING and SIGNAL switches are spring-loaded switches and normally are in the midposition and METER position respectively.		
3.	OPERATION During operation be alert for any evidence of unusual performance; check for burned-out lamps and fuses. Tap switches while observing meter indications for erratic actions.	1.0

Table 4-2. Intermediate Preventive Maintenance Checks and Services

Sequence No.	ITEM TO BE INSPECTED PROCEDURE	Work time (M/H)
1.	EQUIPMENT UNIT Check to see that the unit is complete.	0.5
2.	CABLES AND CONNECTORS Check the power and test cables for cuts, kinks, and frayed insulation. Repair as necessary. Refer to higher level of maintenance for replacement of cables.	1.5
3.	HINGES, HANDLES, FASTENERS, FRONT PANEL MOUNTING SCREWS AND COVER GASKETS a. Hand-check hinges, handles, fasteners and front panel mounting screws for looseness; tighten if possible; otherwise, refer to higher level of maintenance for repair or replacement. b. Check cover gasket for cracks or deterioration: Refer to higher level of maintenance for replacement.	0.5 0.5
4.	EXTERIOR SURFACES Check the exterior metal surfaces of the interphone test set case, cover, and front panel for rust or cor-	0.5

Sequence No.	ITEM TO BE INSPECTED PROCEDURE	Work time (M/H)
	rosion and bare spots. Touch up paint or refinish in accordance with paragraph 4-4.	

Table 4-3. Periodic Preventive Maintenance Checks and Services

Sequence No.	ITEM TO BE INSPECTED PROCEDURE	Work time (M/H)
1.	PUBLICATIONS See that all publications pertinent to this equipment are on hand, complete, and usable. See that all applicable changes are on hand.	0.5
2.	MODIFICATION WORK ORDERS (MWO's) See that all urgent MWO's have been applied and that all normal MWO's have been scheduled. Check to see that MWO stencils on the equipment are legible.	0.5
3.	FUSES AND LAMPS Inspect seating of fuses and lamps. Do not remove, rock, or twist these items to inspect them. Use only direct pressure to insure that item is fully seated.	0.5
4.	EQUIPMENT CONNECTOR AND MATING CABLE CONNECTOR Engage the test cable plug to equipment mating connector, SELF TEST RECEPTACLE J8; check for ease of engagement and snug fit.	0.5
5.	EQUIPMENT OPERATION (SELF-TEST) Perform self-test function in accordance with instructions contained in paragraph 4-8.	0.1

4-7. Cleaning Instructions.

All exterior surfaces of the equipment should be free of dirt, grease, and fungus. Perform the following procedure as specified in the preventive maintenance checks and services tables.

a. Remove moisture and loose dirt with a clean, soft cloth.

WARNING

The fumes of trichloroethane are toxic. Provide thorough ventilation whenever used. DO NOT use near an open flame. Trichloroethane is not flammable, but exposure of the fumes to an open flame converts the fumes to highly toxic, dangerous gases.

b. Remove grease, fungus, and ground-in dirt from the exterior surfaces with a clean cloth dampened (not wet) with trichloroethane. Wipe dry with a clean, dry, lint-free cloth.

c. Clean the front panel and controls; use a clean, soft cloth. If dirt is difficult to remove, dampen the cloth with water; if necessary, use mild soap.

4-8. Equipment Self-Test Procedure.

Perform equipment self-test function as follows:

a. Connect the power cable to a 28-Vdc power source. DO NOT connect any test equipment to the interphone test set.

b. Turn on 28-vdc power source and set POWER-OFF switch to POWER; OPERATE indicator should light.

c. Connect the test cable plug to the SELF TEST RECEPTACLE J8. The SELF TEST indicator should light and the OPERATE indicator should go out.

d. Rotate the RECEIVER SEL switch to OFF and the TRANSMITTER SEL switch to 1. Rotate both the INPUT SEL and OUTPUT SEL switches to R. Hold KEYING switch in RADIO position and then switch and hold at INTER position. KEY ON indicator lights when KEYING switch is in either RADIO or INTER position and goes out when KEYING switch is in midposition.

e. Repeat d above with TRANSMITTER SEL switch in positions 2, 3, and 4 for the TS-1588/AIC and for the TS-1588A/AIC with TRANSMITTER SEL switch in positions 2, 3, 4, and ALTN. The results are the same as for d above.

f. Hold SIGNAL switch to HD MIC and release. KEY ON indicator lights in HD MIC position and goes out when released.

g. Repeat f above with OUTPUT SEL switch at position I. The results are the same as for f above.

h. Place RECEIVER SEL switch to each position 1 through INTER for the TS-1588/AIC and to each position, 1 through EMER for the TS-1588A/AIC. KEY ON indicator lights in each position.

i. Rotate RECEIVER SEL switch to OFF. Rotate TRANSMITTER SEL switch to 1. OUTPUT SEL switch to R. KEY ON indicator lights.

j. Rotate INPUT SEL switch to T, and then to I. KEY ON indicator should go out.

k. Disconnect test cable plug from SELF TEST RECEPTACLE J8. SELF TEST indicator goes out and OPERATE indicator lights.

l. Set POWER-OFF switch to OFF. OPERATE indicator goes out.

m. Turn off 28-vdc power source.

n. Disconnect the power cable from the 28-vdc power source.

o. Place the test cable and power cable in the storage compartment and close the cover of the interphone test set.

Section IV. TROUBLESHOOTING AND MAINTENANCE OF TEST SET, RADIO TS-1588(*)/AIC

4-9. Troubleshooting of Test Set, Radio TS-1588(*)/AIC.

Repair of the interphone test set at organizational level is limited to replacement of indicator lamps, fuses and knobs. Troubleshooting of the interphone test set is accomplished by performing the self-test procedure contained in paragraph 4-8. Corrective actions authorized are as follows:

a. If indicators do not light when indicated, check the lamp by depressing the PRESS TO TEST ring on the lampholder. Lamp replacement instructions are contained in paragraph 4-10.

b. Check the fuse and replace if necessary if the OPERATE indicator does not light when the POWER-OFF switch is set to POWER.

c. Refer all other malfunctions to the next higher category of maintenance.

4-10. Removal and Replacement.

Procedures for removal and replacement of knobs, lamps, and fuses are given in *a* through *c* below.

a. Removal and Replacement of Knobs.

(1) Loosen the setscrews on the knob and pull the knob from its shaft.

(2) Replace the new knob on the shaft and tighten the setscrews.

b. Removal and Replacement of Indicator Lamps.

(1) Unscrew (counterclockwise) the glass indicator jewel assembly and remove it to expose the lamp.

(2) Press in on the lamp and turn it counterclockwise to unlock.

(3) Remove the lamp from its lampholder.

(4) Insert the new lamp in the lampholder.

(5) Push the lamp in and twist it clockwise to lock.

(6) Screw (clockwise) the glass indicator jewel assembly into the lampholder.

c. Removal and Replacement of Fuses.

(1) Press in on the fuse cap and turn it counterclockwise.

(2) Remove the fuse cap and the fuse from its holder.

(3) Insert the new fuse in the fuse cap.

(4) Replace the fuse cap and fuse into its holder.

(5) Press in on the fuse cap and turn it clockwise to lock.

APPENDIX A REFERENCES

The following is a list of publications available to the organizational maintenance man of Test Set, Radio TS-1588(*)/AIC.

DA Pam 310-4	Index of Technical Manuals, Technical Bulletins, Supply Manuals (Types 7, 8, and 9), Supply Bulletins, and Lubrication Orders.
DA Pam 310-7	US Army Equipment Index of Modification Work Orders.
SB 11-573	Painting and Preservation Supplies Available for Field Use for Electronics Command Equipment.
SB 38-100	Preservation, Packaging, Packing, and Marking Materials, Supplies, and Equipment Used by the Army.
TB 746-10	Field Instructions for Painting and Preserving Electronics Command Equipment.
TM 11-5017	Output Meters TS-585A/U, TS-585B/U, TS-585C/U, and TS-585D/U (TO 33A1-7-23-1).
TM 11-5831-201-20	Organizational Maintenance Manual: Control, Intercommunication Set C-1611D/AIC and Discriminator, Discrete Signal MD-736/A.
TM 11-5965-215-15	Operator, Organizational, Field and Depot Maintenance Manual: Headset-Microphone H-101A/U.
TM 11-6130-246-12	Operator's and Organizational Maintenance Manual: Power Supply PP-1104C/G (with Instructions for Use as Battery Charger).
TM 11-6625-239-12	Operator's and Organizational Maintenance Manual: Electronic Multimeters TS-505A/U and TS-505B/U and Multimeters TS-505C/U and TS-505D/U.
TM 11-6625-355-12	Operator's Organizational Maintenance Manual: Audio Oscillators TS-421/U and TS-421A/U.
TM 11-6625-441-20P	Organizational Maintenance Repair Parts and Special Tool Lists: Test Sets TS-1588/AIC and TS-1588A/AIC (FSN 6625-895-664 and FSN 6625-239-6010).
TM 38-750	The Army Maintenance Management System (TAMMS).
TM 740-90-1	Administrative Storage of Equipment.
TM 750-244-2	Procedures for Destruction of Electronics Materiel to Prevent Enemy Use (Electronics Command).

APPENDIX C MAINTENANCE ALLOCATION

Section I. INTRODUCTION

C-1. General

This appendix provides a summary of the maintenance operations for TS-1588/AIC and TS-1588A/AIC. It authorizes categories of maintenance for specific maintenance functions on repairable items and components and the tools and equipment required to perform each function. This appendix may be used as an aid in planning maintenance operations.

C-2. Maintenance Function

Maintenance functions will be limited to and defined as follows:

- a. Inspect.* To determine the serviceability of an item by comparing its physical, mechanical, and/or electrical characteristics with established standards through examination.
- b. Test.* To verify serviceability and to detect incipient failure by measuring the mechanical or electrical characteristics of an item and comparing those characteristics with prescribed standards.
- c. Service.* Operations required periodically to keep an item in proper operating condition, i.e., to clean (decontaminate), to preserve, to drain, to paint, or to replenish fuel, lubricants, hydraulic fluids, or compressed air supplies.
- d. Adjust.* To maintain, within prescribed limits, by bringing into proper or exact position, or by setting the operating characteristics to the specified parameters.
- e. Align.* To adjust specified variable elements of an item to bring about optimum or desired performance.
- f. Calibrate.* To determine and cause corrections to be made or to be adjusted on instruments or test measuring and diagnostic equipments used in precision measurement. Consists of comparisons of two instruments, one of which is a certified standard of known accuracy, to detect and adjust any discrepancy in the accuracy of the instrument being compared.
- g. Install.* The act of emplacing, seating, or fixing into position an item, part, module (component or assembly) in a manner to allow the proper functioning of the equipment or system.
- h. Replace.* The act of substituting a serviceable like type part, subassembly, or module (component or assembly) for an unserviceable counterpart.
- i. Repair.* The application of maintenance services (inspect, test, service, adjust, align, calibrate,

replace) or other maintenance actions (welding, grinding, riveting, straightening, facing, re-machining, or resurfacing) to restore serviceability to an item by correcting specific damage, fault, malfunction, or failure in a part, subassembly, module (component or assembly), end item, or system.

j. Overhaul. That maintenance effort (service/action) necessary to restore an item to a completely serviceable/operational condition as prescribed by maintenance standards (i.e., DMWR) in appropriate technical publications. Overhaul is normally the highest degree of maintenance performed by the Army. Overhaul does not normally return an item to like new condition.

k. Rebuild. Consists of those services/actions necessary for the restoration of unserviceable equipment to a like new condition in accordance with original manufacturing standards. Rebuild is the highest degree of materiel maintenance applied to Army equipment. The rebuild operation includes the act of returning to zero those age measurements (hours, miles, etc.) considered in classifying Army equipments/components.

C-3. Column Entries

a. Column 1, Group Number. Column 1 lists group numbers, the purpose of which is to identify components, assemblies, subassemblies, and modules with the next higher assembly.

b. Column 2, Component/Assembly. Column 2 contains the noun names of components, assemblies, subassemblies, and modules for which maintenance is authorized.

c. Column 3, Maintenance Functions. Column 3 lists the functions to be performed on the item listed in column 2. When items are listed without maintenance functions, it is solely for purpose of having the group numbers in the MAC and RPSTL coincide.

d. Column 4, Maintenance Category. Column 4 specifies, by the listing of a "worktime" figure in the appropriate subcolumn(s), the lowest level of maintenance authorized to perform the function listed in column 3. This figure represents the active time required to perform that maintenance function at the indicated category of maintenance. If the number or complexity of the tasks within the listed maintenance function vary at different maintenance categories, appropriate "worktime"

figures will be shown for each category. The number of task-hours specified by the "worktime" figure represents the average time required to restore an item (assembly, subassembly, component, module, end item or system) to a serviceable condition under typical field operating conditions. This time includes preparation time, troubleshooting time, and quality assurance/quality control time in addition to the time required to perform the specific tasks identified for the maintenance functions authorized in the maintenance allocation chart. Subcolumns of column 4 areas follows:

- C - Operator/Crew
- O - Organizational
- F - Direct Support
- H - General Support
- D - Depot

e. Column 5, Tools and Equipment. Column 5 specifies by code, those common tool sets (not individual tools) and special tools, test, and support equipment required to perform the designated function.

f. Column 6, Remarks. Column 6 contains an alphabetic code which leads to the remark in section IV, Remarks, which is pertinent to the item opposite the particular code.

C-4. Tool and Test Equipment Requirements (sec III)

a. Tool or Test Equipment Reference Code. The numbers in this column coincide with the numbers

used in the tools and equipment column of the MAC. The numbers indicate the applicable tool or test equipment for the maintenance functions.

b. Maintenance Category. The codes in this column indicate the maintenance category allocated the tool or test equipment.

c. Nomenclature. This column lists the noun name and nomenclature of the tools and test equipment required to perform the maintenance functions.

d. National/NATO Stock Number. This column lists the National/NATO stock number of the specific tool or test equipment.

e. Tool Number. This column lists the manufacturer's part number of the tool followed by the Federal Supply Code for manufacturers (5-digit) in parentheses.

C-5. Remarks (sec IV)

a. Reference Code. This code refers to the appropriate item in section II, column 6.

b. Remarks. This column provides the required explanatory information necessary to clarify items appearing in section II.

SECTION II MAINTENANCE ALLOCATION CHART
FOR
 TEST SET, RADIO TS-1588/AIC AND TS-1588A/AIC

TM 11-6625-441-12

(1) GROUP NUMBER	(2) COMPONENT/ASSEMBLY	(3) MAINTENANCE FUNCTION	(4) MAINTENANCE CATEGORY					(5) TOOLS AND EQPT.	(6) REMARKS
			C	O	F	H	D		
00	TEST SET, RADIO TS-1588/AIC AND TS-1588A/AIC TM 11-6625-441-12, 34, 20P, 34P	Inspect		0.1					A
		Service		0.2				1,2	
		Test		0.3				1,2	
					0.5			1,3	
		Repair		0.2		0.5		1,3	
		Repair			0.5		1.0	1,2	
01	CABLE, POWER, ELECTRICAL JC 580 TYPE JO (81348)	Repair					8.0	1,3	B
		Overhaul						1,3	
		Inspect		0.1				1,2	
02	CABLE ASSEMBLY, POWER, ELECTRICAL, SME 374333 (80063)	Test		0.2				1,3	A
		Repair			0.2			1,2	
		Inspect		0.1				1,3	
		Test		0.2				1,2	
		Repair			2.0			1,3	

Change 1 c-3

SECTION III TOOL AND TEST EQUIPMENT REQUIREMENTS
 FOR
 TEST SET, RADIO TS-1588/AIC AND TS-1588/AIC

TOOL OR TEST EQUIPMENT REF CODE	MAINTENANCE CATEGORY	NOMENCLATURE	NATIONAL/NATO STOCK NUMBER	TOOL NUMBER
1	O, F, H, D	MULTIMETER AN/USM-223	6625-00-999-7465	
2	O	TOOL KIT TK-101/G	5180-00-064-5178	
3	F, H, D	TOOL KIT TK-105/G	5180-00-610-8177	

SECTION IV. REMARKS

REFERENCE CODE	REMARKS
A	VISUAL
B	REPAIR BY REPLACEMENT OF DEFECTIVE KNOBS, LAMPS, OR FUSES.

By Order of the Secretary of the Army:

FRED C. WEYAND
General, United States Army
Chief of Staff

Official:

VERNE L. BOWERS
Major General, United States Army
The Adjutant General

Distribution:

To be distributed in accordance with DA Form 12-36A (qty rqr block no. 1160), Organizational avionics test equipment literature requirements for TS-1588()/AIC.

RECOMMENDED CHANGES TO EQUIPMENT TECHNICAL PUBLICATIONS



THEN...JOT DOWN THE
DOPE ABOUT IT ON THIS FORM.
CAREFULLY TEAR IT OUT, FOLD IT
AND DROP IT IN THE MAIL.

SOMETHING WRONG WITH PUBLICATION

FROM: (PRINT YOUR UNIT'S COMPLETE ADDRESS)

DATE SENT

PUBLICATION NUMBER

PUBLICATION DATE

PUBLICATION TITLE

BE EXACT PIN-POINT WHERE IT IS

PAGE
NO.

PARA-
GRAPH

FIGURE
NO.

TABLE
NO.

IN THIS SPACE, TELL WHAT IS WRONG
AND WHAT SHOULD BE DONE ABOUT IT.

TEAR ALONG PERFORATED LINE

PRINTED NAME, GRADE OR TITLE AND TELEPHONE NUMBER

SIGN HERE

